

# **SOFA MURPHY BED**

---

## **ASSEMBLY INSTRUCTIONS**

---

## INTRODUCTION

---

Welcome to your new Sofa Murphy bed!

This guide is designed to provide you with step by step instructions using both pictures and words for assembly of the Sofa Murphy Bed. Holes have been pre-drilled, and all screw sizes have been included for your convenience.

The Murphy bed you have purchased has been designed with both quality and safety in mind. The nitrogen gas pistons (included) are designed to cycle the up and down movement gently without allowing the bed to fall. It will be required to assemble with two adults as the frame is heavy and some of the screw holes are difficult to reach while holding the frame. The hardwood, finish and quality workmanship are sure to add eloquence and convenience to your room for many years to come.

Lancaster Handcraft, LLC assumes no liability for any damage done to either the assembler, the product, or the area the product is placed.

Thank you for your business,  
Lancaster Handcraft, LLC

## **!! ATTENTION !!**

While we trust that the bed you've purchased from Lancaster Handcraft can be built by our customers, it is imperative that the instructions found below be precisely followed. There are many factors that can contribute to the bed not functioning as designed if instructions are not followed properly, and therefore we urge customers and/or contractors to pay special attention to this manual.

We've used these "ATTENTION" boxes to bring extra focus to more difficult steps, helping to ensure they are done with care and attention.

## Additional Tools

---



Impact Driver  
(or drill)



Stud Finder



A Buddy



1 1/4"  
Pocket Screw  
(H1)



1"  
Flat Head  
(H2)



3/4"  
Washer Head  
(H3)



3"  
Mounting Screw  
(H4)



2"  
Desk Screw  
(H5)

Front Panel  
Hardware



# Provided Pieces

---



Crown



Assembly Strip (2x)



Metal Braces (2x)



Double Base Board  
(not included with Sofa bed)



Headboard Mattress Stopper



Back Stabilizer Board



Wood Slats (6x)



Head Board



Floor Spacer Board

# Definitions

---

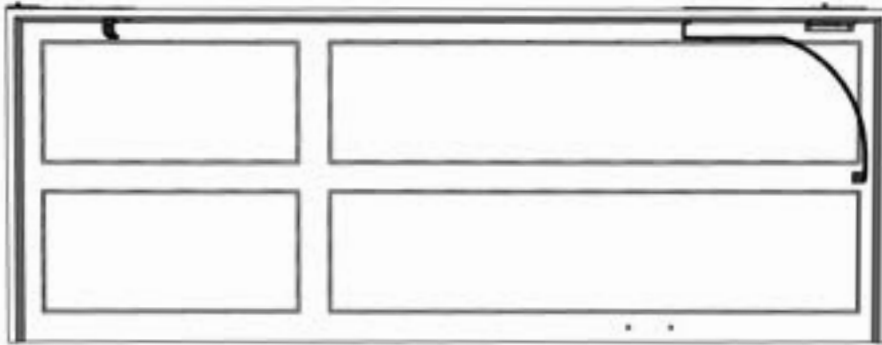

Front Panel (2x)

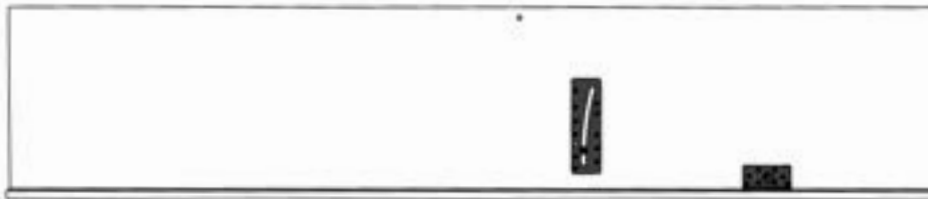

Side Panel (2x)

## Pro Tips:

- **Protect Your Space:** Lay down blankets or material to keep the floor and bed parts safe from scratches.
- **Screws:** Ensure you use the assigned screws for install as incorrect lengths can pierce the wood
- **Two-Person Team:** This process will be much easier & safer with two people.
- **Bottom & Top:** For this installation, think of the “bottom” of the bed as where your **HEAD** will be when sleeping on the mattress.

### STEP 1: Prepare the Space

Choose the exact location for the bed and clear the area. Laying down blankets or anything soft to protect bed and floors

### STEP 2: Attach Handles

Secure the included handles to the front panels using the screws provided in the hardware kit.

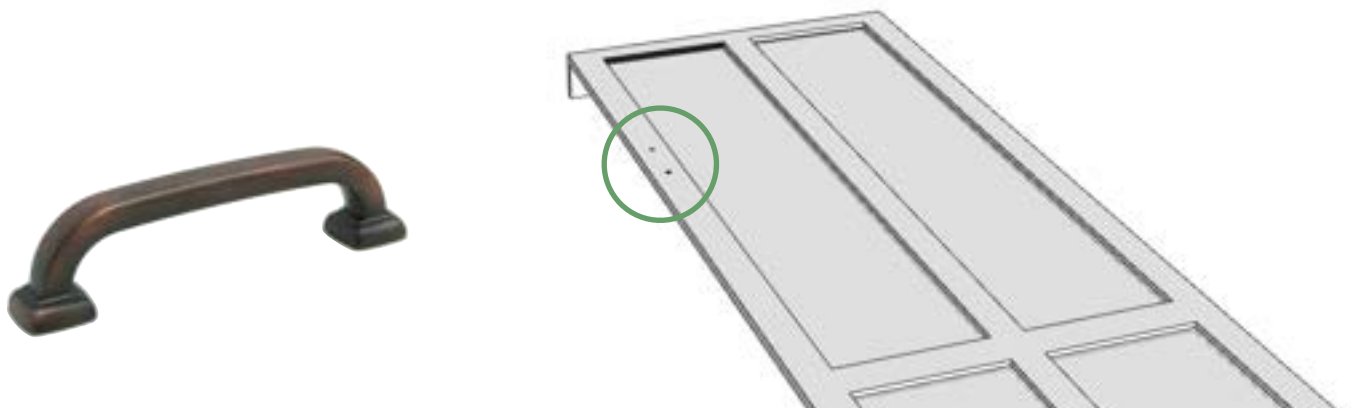

### STEP 3: Position Front Panels

Lay the front panels **face down** with handles touching the floor. Position the “bottom” of the bed about 14” away from the wall.

### STEP 4: Place the Assembly Strips

Slide the assembly strips upright **under the mattress straps** and snug against the inside base of the front panels. This will hold the panels together.

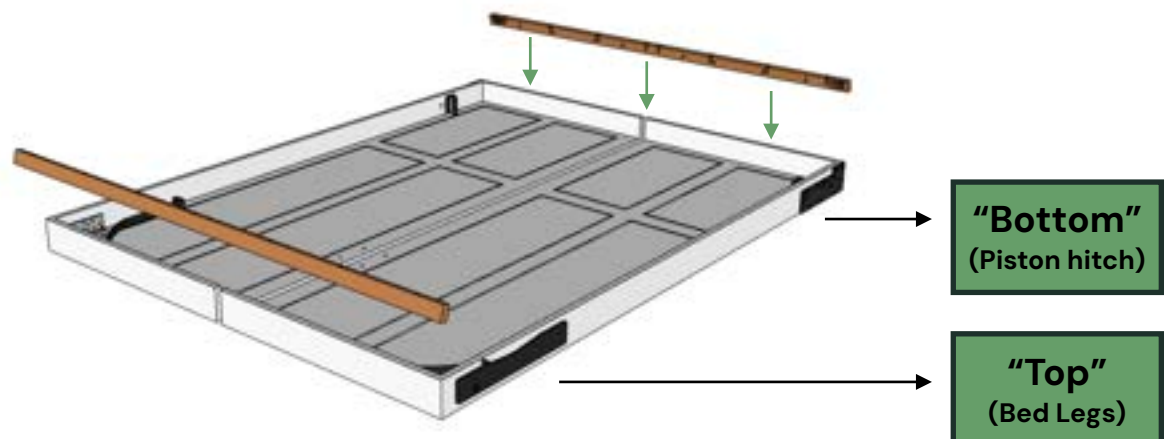

## Pro Tip:

- **Pocket Screws (H1):** You'll notice several pieces with pre-cut "pockets," where 1/4" pocket screws will mostly be used.

## STEP 5: Attach The Assembly Strips

Start with the "bottom", securing the assembly strip to one panel with **Pocket Screws (H1)** in the pre-cut pockets. For the other side, make sure the two panels are aligned and pressed tightly together with no gaps. Repeat step for "top" assembly strip.

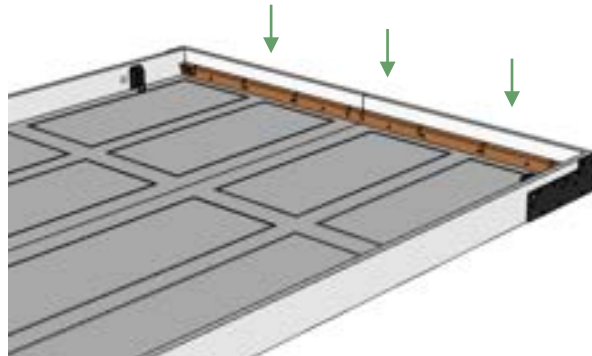

## STEP 6: Add Metal Beams

Place the metal beams along the marked areas on the panels. **Use 3/4" Screws (H3)** in pre-drilled holes to secure the beams. Ensure the panels stay flush.

## Pro Tip:

- Metal beam markings will be drawn on and are a general placeholder.

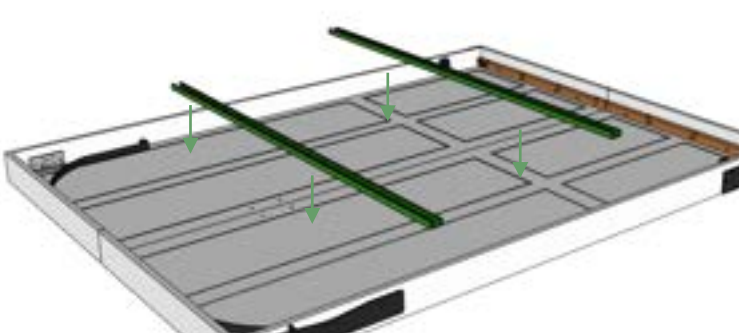

## STEP 7: Position Wooden Slats

Evenly space six flat wooden slats (about 4" apart) between the assembly strips and metal beams. **Use 1" Screws (H2)** to attach, making sure to screw into the raised section of the panel (this avoids screws piercing through the front). These holes are not pre-drilled and will be screwed directly into the wood. Do not screw the area where handles are located.

### Pro Tip:

- **Wooden Slats:** Wooden slats may not sit flush with the white panels' sides—this is fine. Aim to have even gaps on either side.

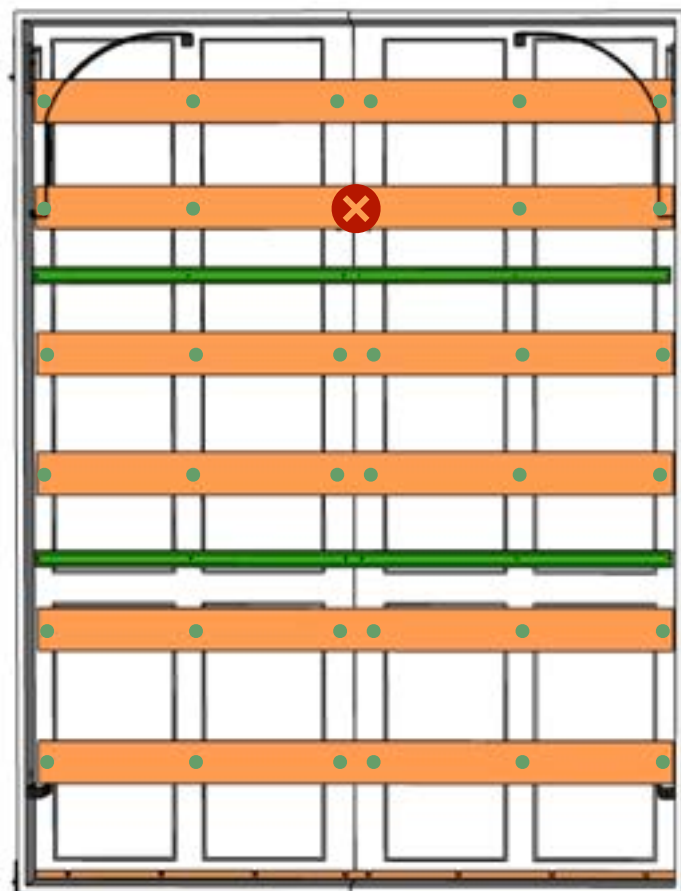
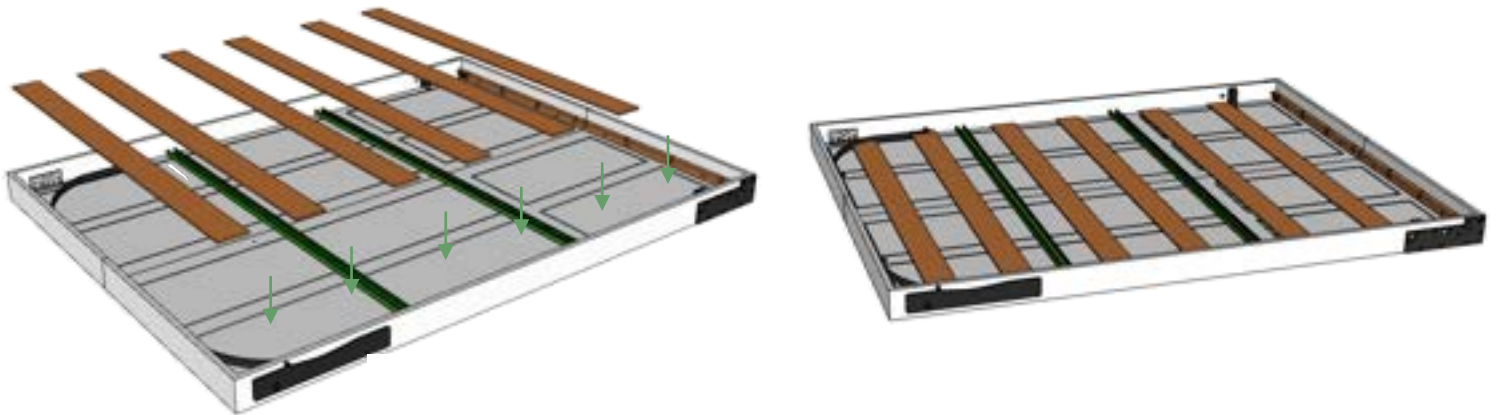

● Insert Screws Here

✗ Do Not Drill Over Handles

**STEP 8: Place Side Panels**

Position the side panels so that the hardware is at the "bottom" of the bed.

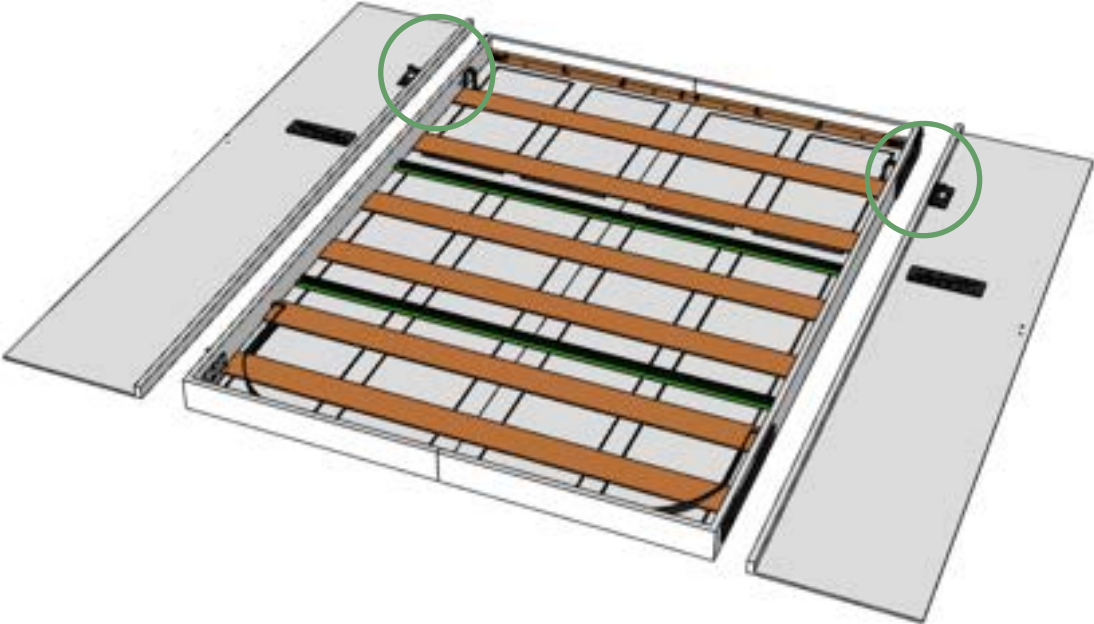

**STEP 9: Remove Rubber Caps**

Remove the rubber caps from the side panel hardware.

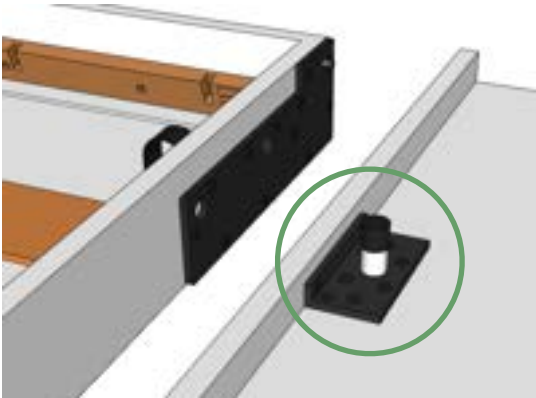

### STEP 10: Set Hardware

Remove the screw and washer from the side panel hardware, keeping the gold ring in place. Set these aside for reattaching.



### STEP 11: Attach Side Panels

Lift side panels and insert the hardware into the pre-drilled hole on front panel. Use the removed screw and washer to attach the side panel to the front panel. **It's normal for the side panel to have a bit of play (movement) even when attached.**

Repeat this step for the other side.

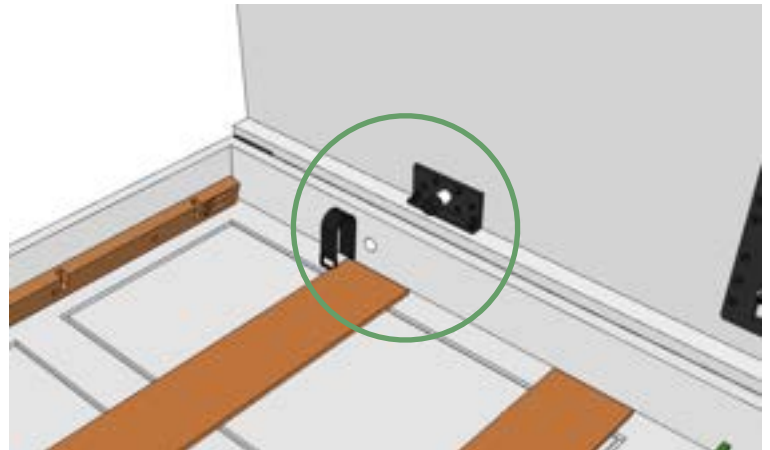
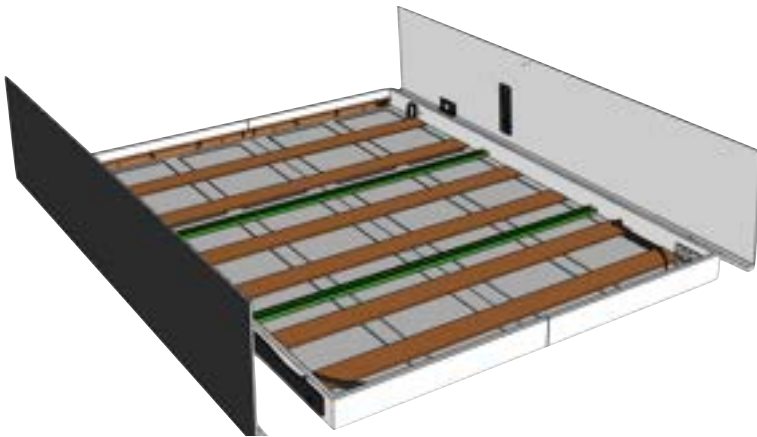

## STEP 12: Position & Secure the Crown

Place the crown piece at the "top" of the bed, aligning with both side panels. The top of the crown will be unfinished, while the bottom will have mattress stopper devices built in. The side panels should slide perfectly into the spaces provided, interlocking snugly with the crown.

Use pocket holes and **Pocket Screws (H1)** on both sides to fasten crown to side panels.

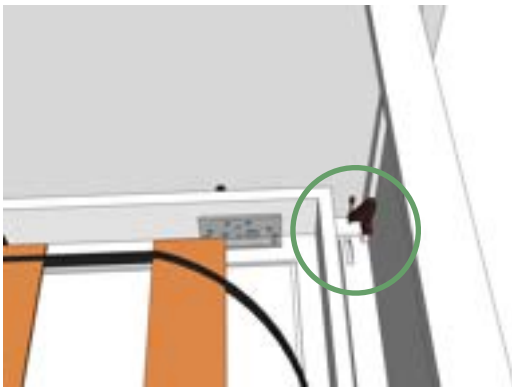
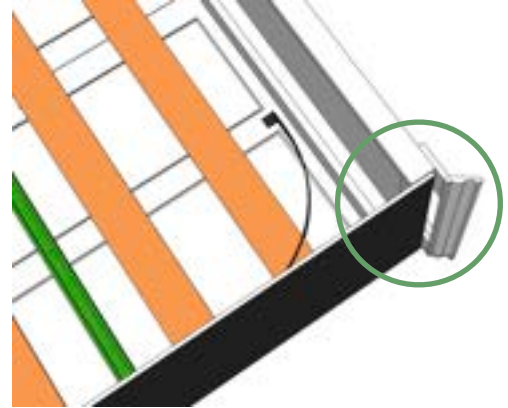
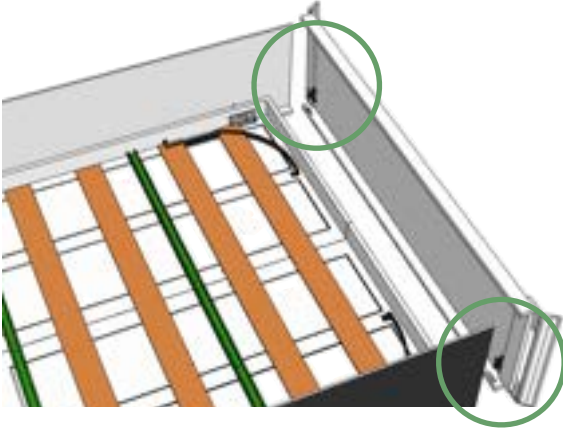

### Pro Tip:

- Mattress stoppers swing down and are adjustable to ensure flush bed.
- A pocket screw will fit into a pocket tucked next to the bed stopper. This pocket won't be able to be reached until later in Step 24.

## STEP 13: Attach the Headboard

Place the headboard face down flush with the side panels. Use the pre-attached wooden dowels to align placement. The pre-routed pockets on the headboard should be facing towards the wall, to later be hidden when bed is lifted. Lift the headboard slightly to make sure it's flush with the side panel, and then attach using **Pocket Screws (H1)**. Repeat on the opposite side.

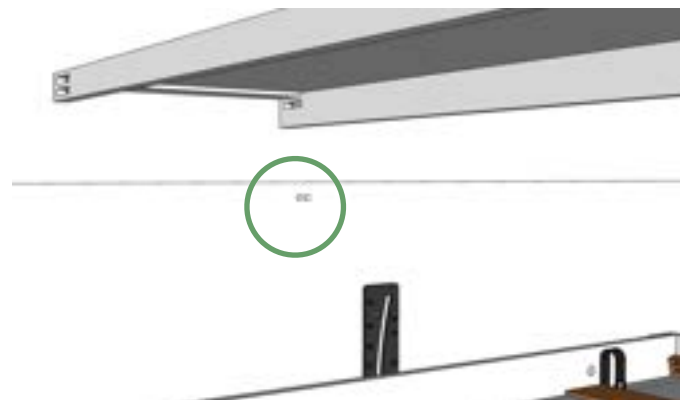
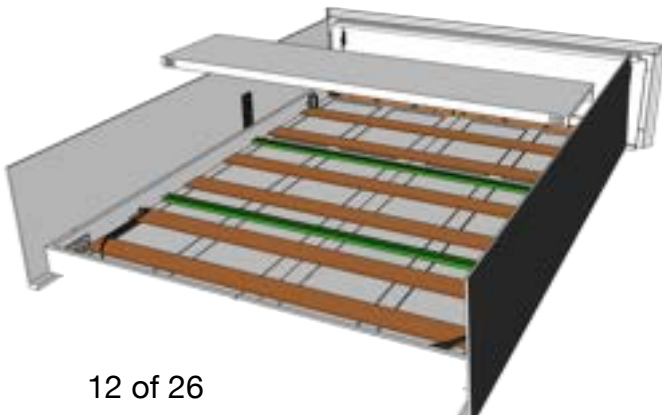

## STEP 14: Attach the Back Stabilizer Board

The back stabilizer board is used to keep the frame square and used as extra mounting if necessary\*. If the room has baseboards, ensure the stabilizer board is fastened high enough to sit above the base board, otherwise place it flush to where the floor will be. **Pockets will face DOWN, away from the "wall" to access in Step 20.** Install stabilizer board flush with the side panels using **Pocket Screws (H1)**.

\*If the floor cannot be screwed into, this board can be used as a connection for a lower wall mount. Drilling into the same studs as the crown in upcoming steps.

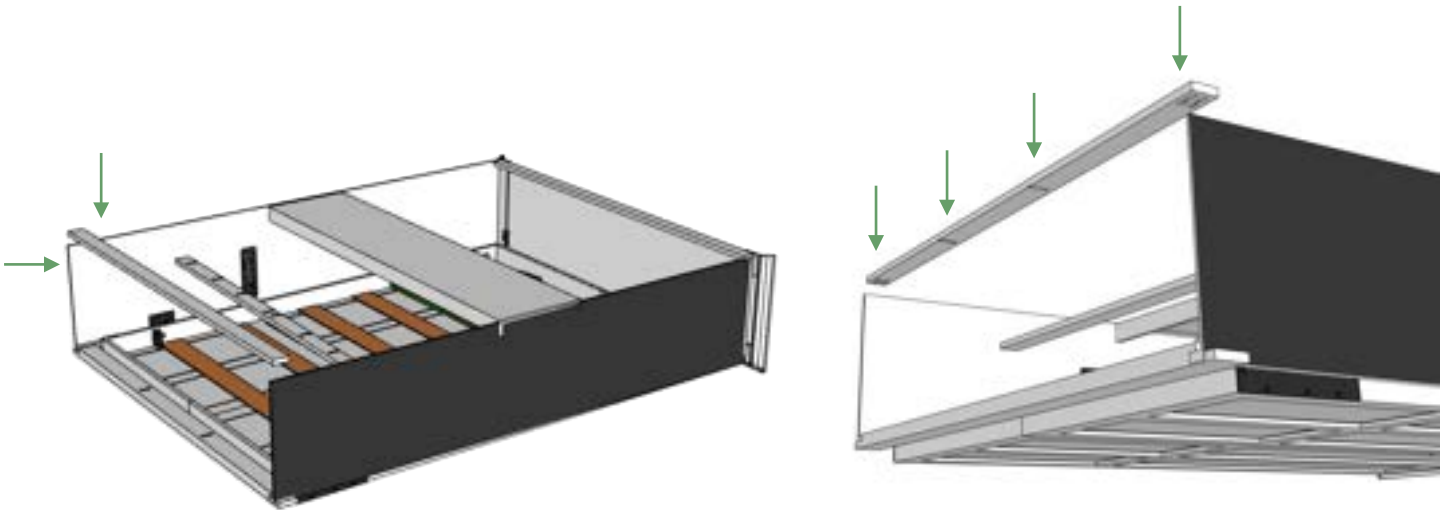

## STEP 15: Attach Floor Spacer Bar

The floor spacer bar is used to keep the side panels the correct distance apart. This bar will sit flush against the bottom of the side panels. This, when raised, will sit flush against the floor. Attached to the side panels using **Pocket Screws (H1)**.

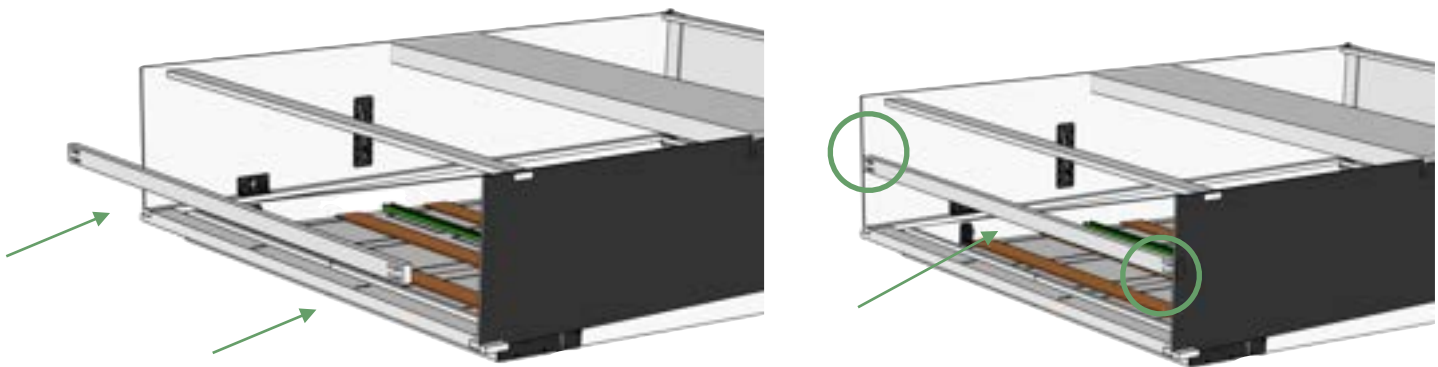

## STEP 16: Lift Side Panels and Position the Bed

Keeping the bed flat on the ground, tilt the side panels and crown upright. Slide the bed into its final position against the wall and remove any blankets from under the panels.

### Pro Tip:

- **Blankets:** Leave blankets under the "top" of the bed to insure floor and bed is not scratched with further movements.



## !! ATTENTION !!

The next few steps will **REQUIRE** two people. Step 18 will have you secure the bed into the wall studs. In order to ensure the front panels of the bed will fit into the side panel frame when raised, the side panels must be made level - Both horizontally and vertically (plumb).

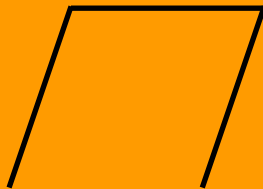

Incorrect

\*exaggerated for manual\*

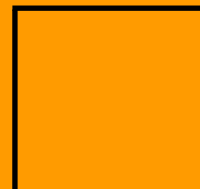

Correct

## STEP 17: Adjust for Even Gaps

Adjust the square of the bed by gently pushing the bottom or top corners of the bed frame to achieve both vertical (plumb) & horizontal level. Take your time to ensure proper level. You may want to close the bed to ensure proper spacing.

**BECAUSE BED IS NOT YET SECURED TO WALL, RAISING THE BED MUST BE DONE WITH A SECOND PERSON AND WITH EXTRA PRECAUTION.**

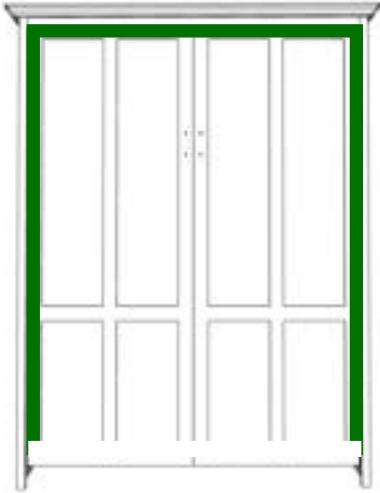

### Pro Tip:

- **Gaps:** The feet of the bed are built to fit perfectly into these 1/2" gaps. Ensure the feet swing freely in this space.

## STEP 18: Secure Bed to Wall & Floor

Use stud finder to find as many studs as possible along the top strip of the crown. It is highly recommended that queen beds be anchored to at **LEAST** three studs.

Use the provided **3 1/2" Mounting Screws (H4)**. Countersinking these screws is recommended.

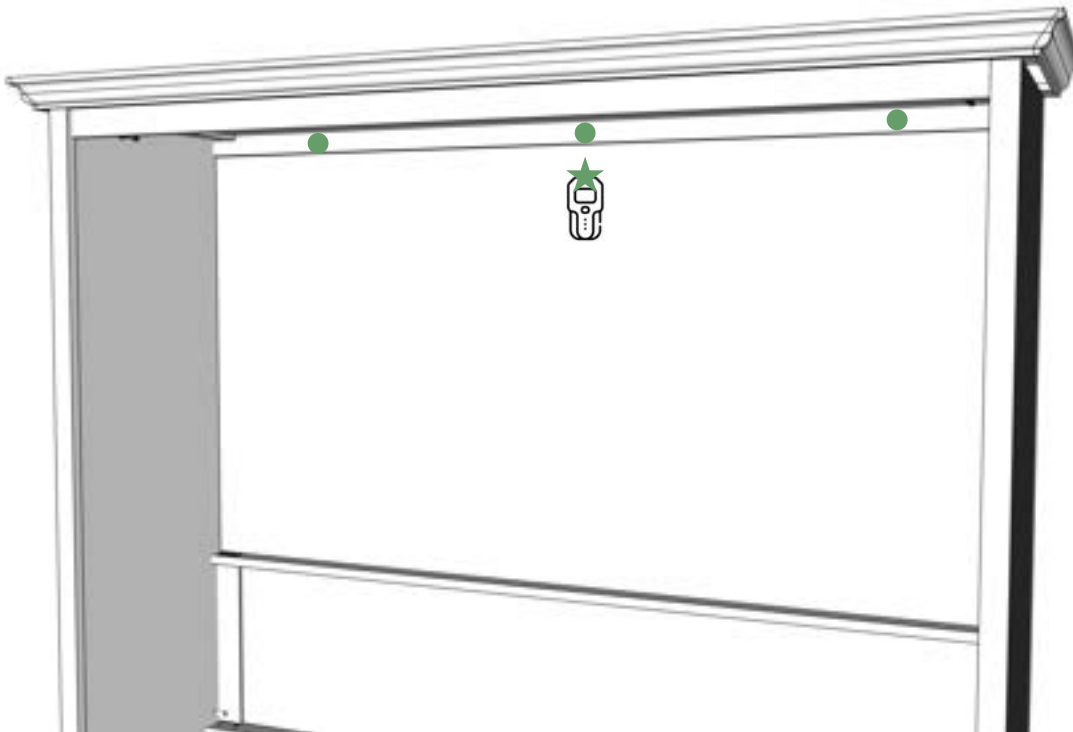

### Pro Tip:

- **Studs:** Most modern homes place studs apart 16" at center, while some older buildings are at 24"
- Please consult a professional if drilling into any stud material other than wood

Once bed is square and secure, if you cannot drill into the floor, use **Pocket Screws (H1)** to secure lower Stabilizer Board from Step 14 to the wall.

## STEP 19: Attach Mattress Stopper

Place mattress stopper at the head of the bed frame. This will prevent the mattress from sliding while the bed is vertical. Use **Pocket Screws (H1)** on the back of the board. **This board will sit centered on the frame and not be flush with the side edges.**

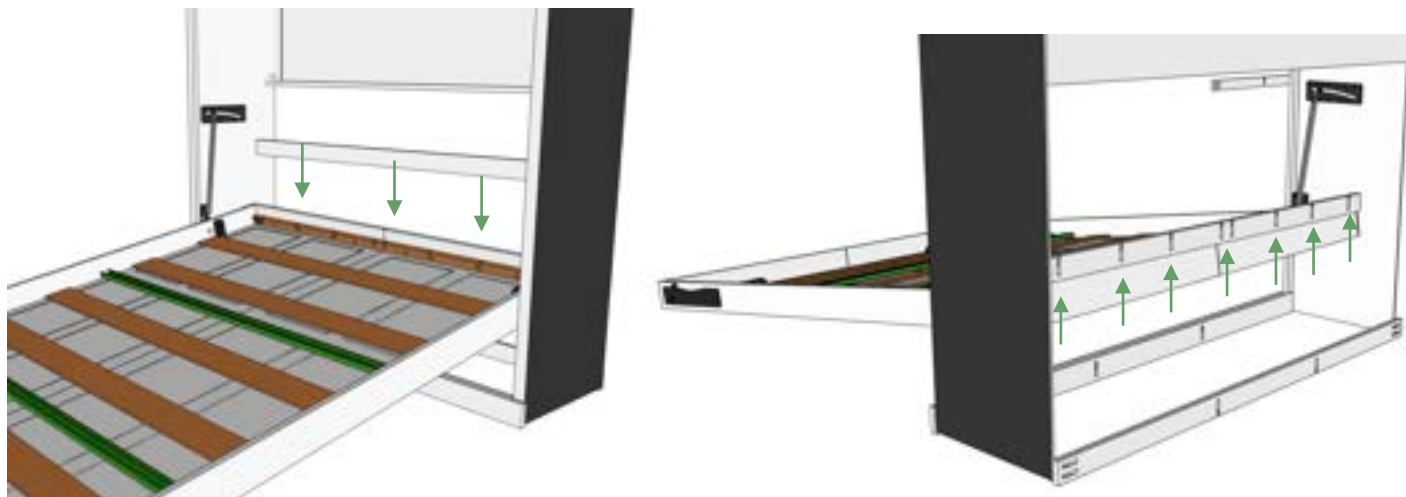

## !! ATTENTION !!

Attaching the pistons can be a complex step as alignments are very precise. Carefully read through instructions for support.

The pistons are shipped fully extended. When the bed is closed and upright, the ball studs will be the same distance apart as the heads of the fully extended piston. You will not be able to attach the pistons to the bed when the bed is open (down).

You will never need to adjust the ball studs attached to the side panel. These have been spaced precisely to work with the bed and repositioning them will cause the bed to not function properly and potentially cause damage.



**DO NOT MOVE**

## STEP 20: Align Pistons

The purpose of this step is to align the piston heads so they will be easier to attach in future steps.

**Step 1:** Attach the **small piston socket** to the **small lower ball stud** on the side of the **front panel**. Align the **large piston socket** with the **large upper ball stud** and rotate it to face the **large ball stud** on the **side panel**.

**Step 2:** Then **detach** the **small piston socket** and **connect** the **large piston socket** to the side panel.

**Step 3:** The piston should now be hanging from the **large socket** at the top, with the **small socket head** no longer attached. You will attach this in later steps.

**Step 1:**

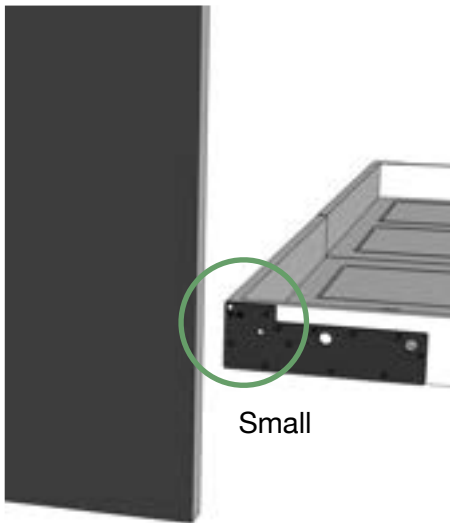

**Step 2:**

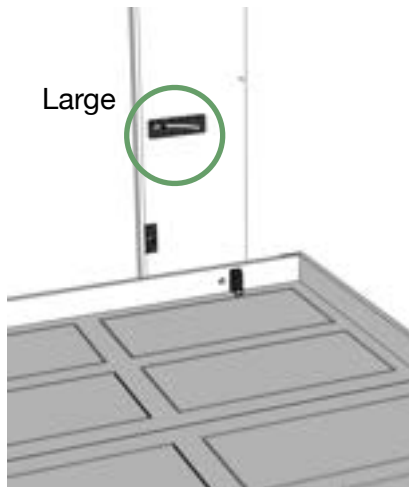

**Step 3:**  
Final Hanging Position



## STEP 21: Lift Bed and Adjust

Raise the "top" of the bed to align with side panels. Remove protective blankets from space.

Check that the bed is flush with the panel sides. If not, adjust the bed stoppers as needed. To confirm proper alignment, ensure the key lock opens and closes smoothly.

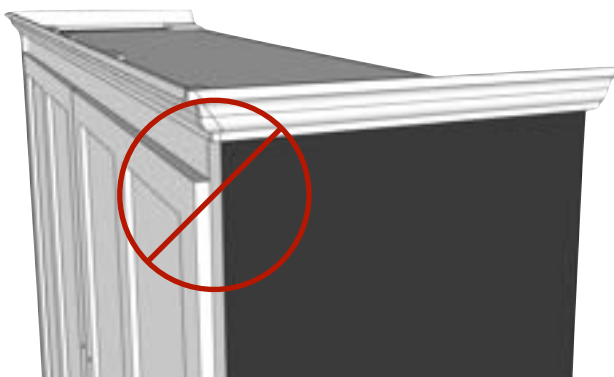

Not Flush  
Needs Adjustment

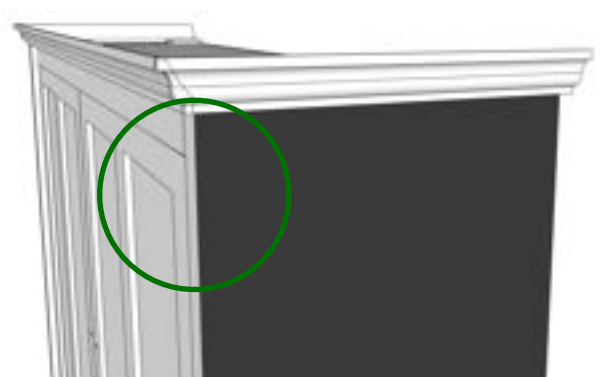

Flush

## STEP 22: Attaching the Pistons

### ANOTHER PERSON IS REQUIRED FOR NEXT STEP!

Ensure that the bed is upright. Lay on the floor and reach under the bottom portion of the bed. The small socket of the piston will be hanging, and, if aligned properly in step 19, should be able to attach to the small ball hitch on the front panel. Repeat attachment on other side.

## !! ATTENTION !!

The pistons often won't quite line up at first. No worries! Simply have the second person push the top of the bed further into the frame to help find the alignment. This will require you to push the rubber bed stoppers up to allow for the bed to push further into the frame.

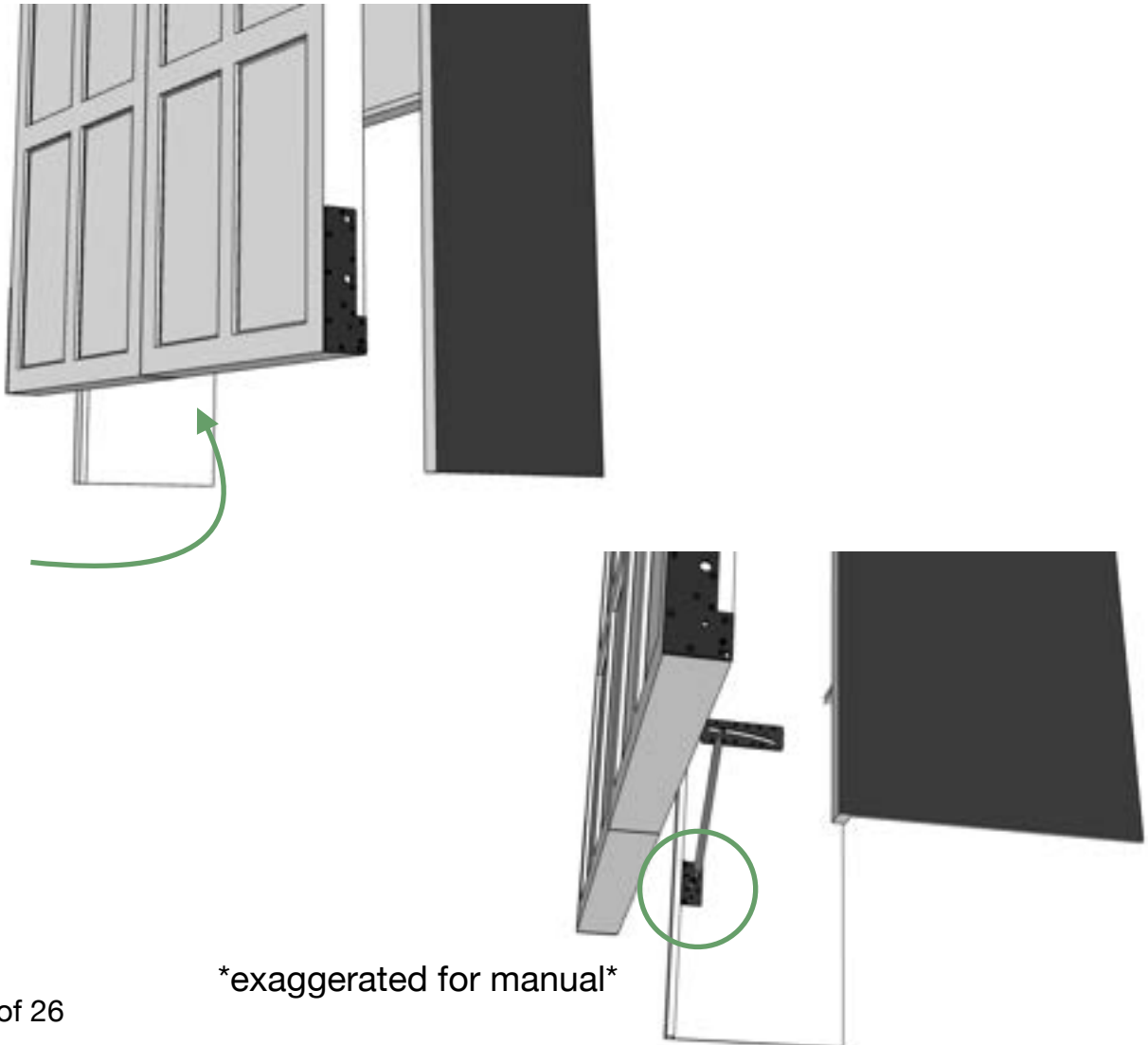

\*exaggerated for manual\*

### STEP 23: Attaching the Double Base Board

Slide the base board into place against the floor, lining up the notches to fit the side panels. Reach inside the bed and drill the side panel to the base board using two **Pocket Screws (H1)**. These holes are **NOT** pre-drilled. Repeat on both sides.

Using the pockets and **Pocket Screws (H1)** drill the base board into the floor for further stabilization.

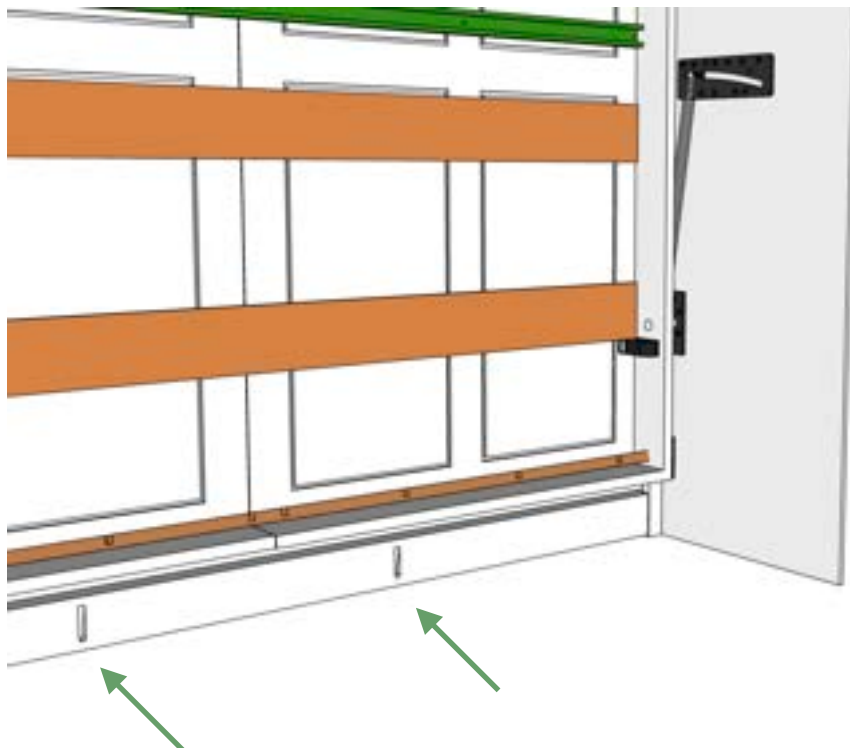
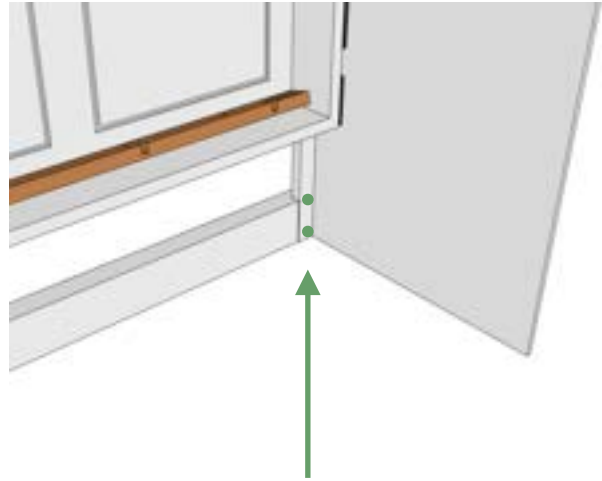
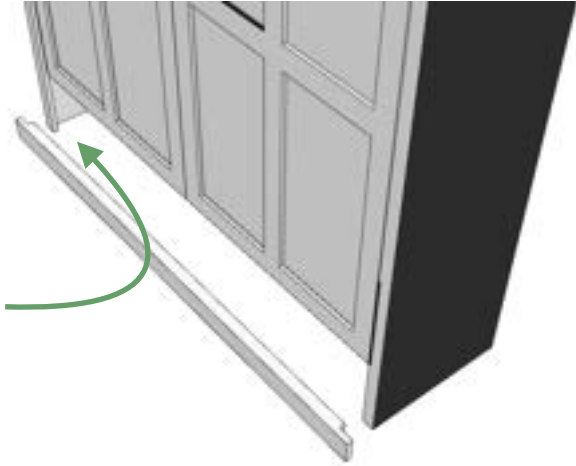

## STEP 24: Attach the Mattress Protector

Use the handles to practice lowering the bed frame down. Pull the bed until you hear the pistons kick in, then release the handles and allow the feet to swing out and touch the floor. Sometimes the legs won't make contact with the floor yet. This is because the pistons are calibrated to bear the weight of the mattress as well. The legs should touch or be very slightly off the floor once the mattress is added.

If feet still don't touch with mattress added, or in the rare occasion feet come down hard onto the floor, then the pistons must be changed out for different weights. Please reach out to Lancaster Handcraft immediately if this occurs.

### DO NOT USE BED WITHOUT PROPERLY CALIBRATED PISTONS.

Screw the provided felt mattress protector to the bed frame using the **3/4" Screws (H3)**. This is used to protect the mattress from the exposed frame. Ensure the corners are screwed in and place multiple screws at different points along the wooden slabs. The four corners and a few along the sides and center will be plenty.

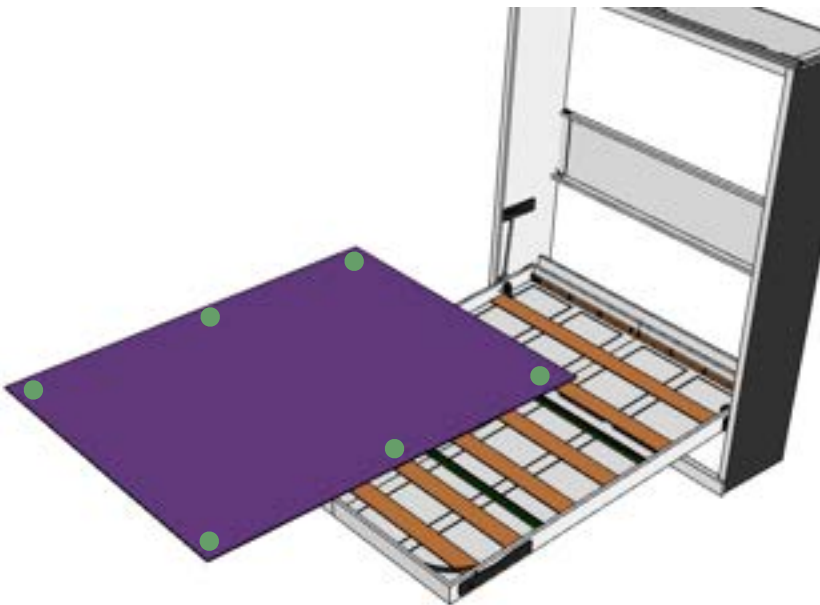

## STEP 25: Final Pocket Screws

Find the pockets we left from Step 12 behind the crown next to the mattress stoppers. Use **Pocket Screws (H1)** for final application.

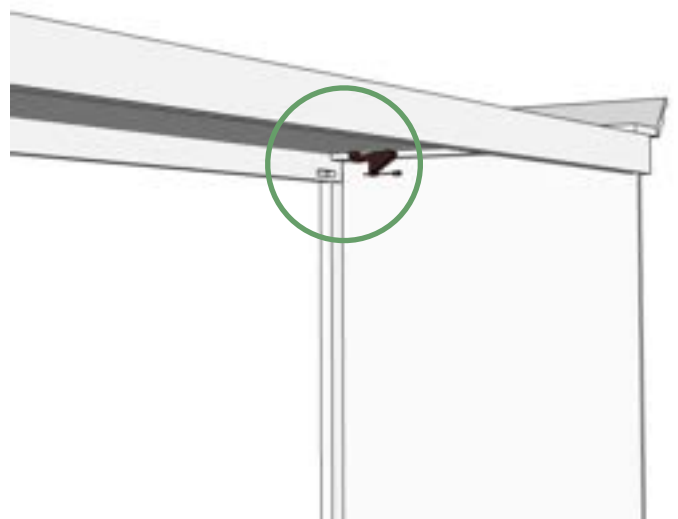

### STEP 26: Attaching the Sofa Back

Align the brackets and slide the sofa back onto the plate on the Murphy bed.



### STEP 27: Contd...

When plates are aligned, screw in the **1" (H2)** screw provided on each side.

## STEP 28: Assembling Sofa Seat & Arms

Lay out sofa parts as shown in the photo.



## STEP 29: Attach Toe Kick

Attach the toe kick to the sofa arms with **1 ¼" (H1)** screws.



### STEP 30: Attach Center Support

Attach center support between the arms with 1 ¼" (H1) screws.



### STEP 31: Install Seat

Place seat on center support so that the front of the cushion aligns with the base. Add 1 ¼" (H1) screws to holes under the the seat at toe kick and in the back under the center support.



### STEP 32: Attach Sofa to Bed

Slide the sofa seat and arms into place. Open the Murphy Bed over the seat cushion to reveal the pre-drilled holes on the inside of the face frame. Attach sofa arms with **2" (H5)** using these holes.



## STEP 26: Add Mattress, Mattress Straps & Enjoy

Lift mattress onto bed. Lift straps over mattress on bottom corners pulling them tight to prevent movement. The strap at the head will be pulled tightly across the back edge of the mattress. Lift and lower the bed with mattress on, ensuring the opening and closing of the bed is smooth and never abrupt.

Once satisfied, step back and admire your new Amish made Murphy Bed from Lancaster Handcraft.

### Pro Tip:

- **Bedding:** The bed can be raised with bedding still on. Bedding can be made over the straps and ideally with a “hotel tuck” ensuring no loose sheets get caught in the movements.
- **Comforters:** Can be tucked in and left on the bed while up.
- **Pillows:** Pillows should be removed before raising the bed as they will likely fall behind the panels.



Should you run into any issues, never hesitate to reach out to our team, who will be more than happy to assist you as best they can.

Thank you for choosing Lancaster Handcraft

# CABINETS

(18" Standard)

If you have purchased cabinets with your Murphy Bed, the installation is very simple!

Slide the cabinet so the unfinished panel sits up against the bed.

Reaching into the cabinet, drill into the inside corner of the cabinet that is closest to you and into the bed.

From top to bottom of the open space, use at least 8 Pocket Screws to ensure the cabinet is secured safely to the bed.

*\*If cabinets are larger than 18", they must also be screwed into wall studs for added safety.\**

